

REVISION HISTORY			
REV	DESCRIPTION	DATE	EO NUMBER
1	Initial release	06/24/2015	NA
2	Added Note 1, sheet 1	12/02/15	

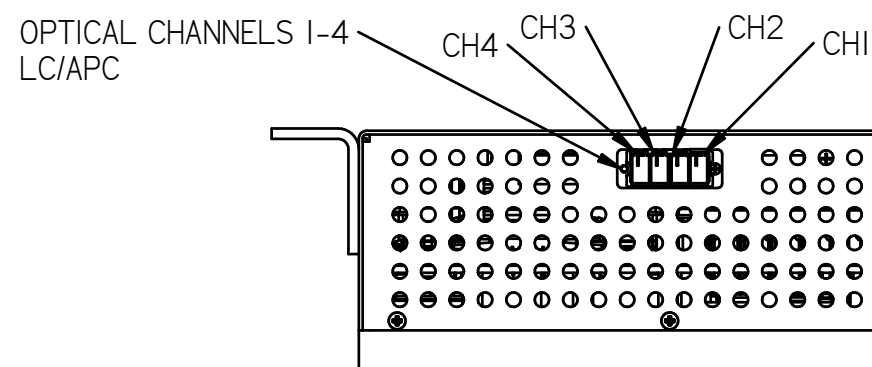
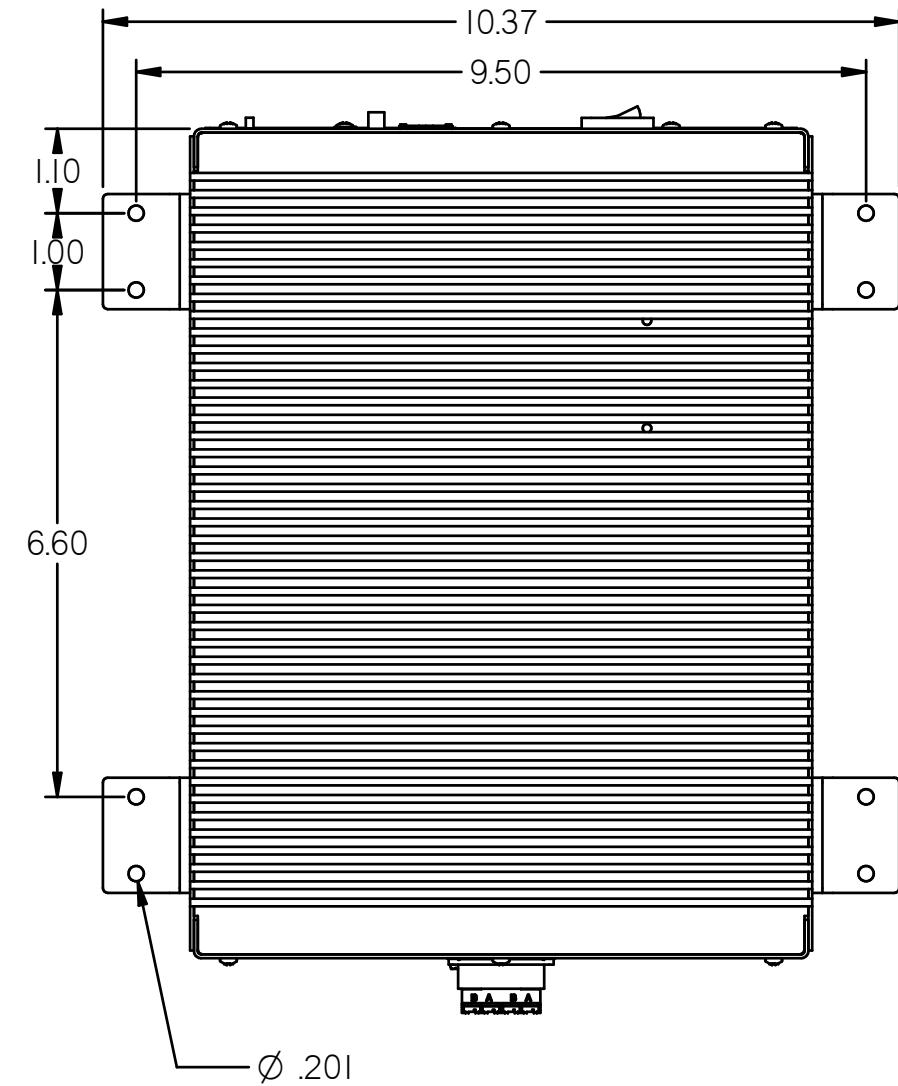
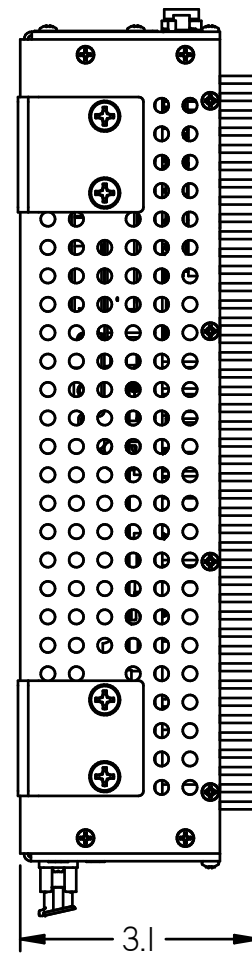
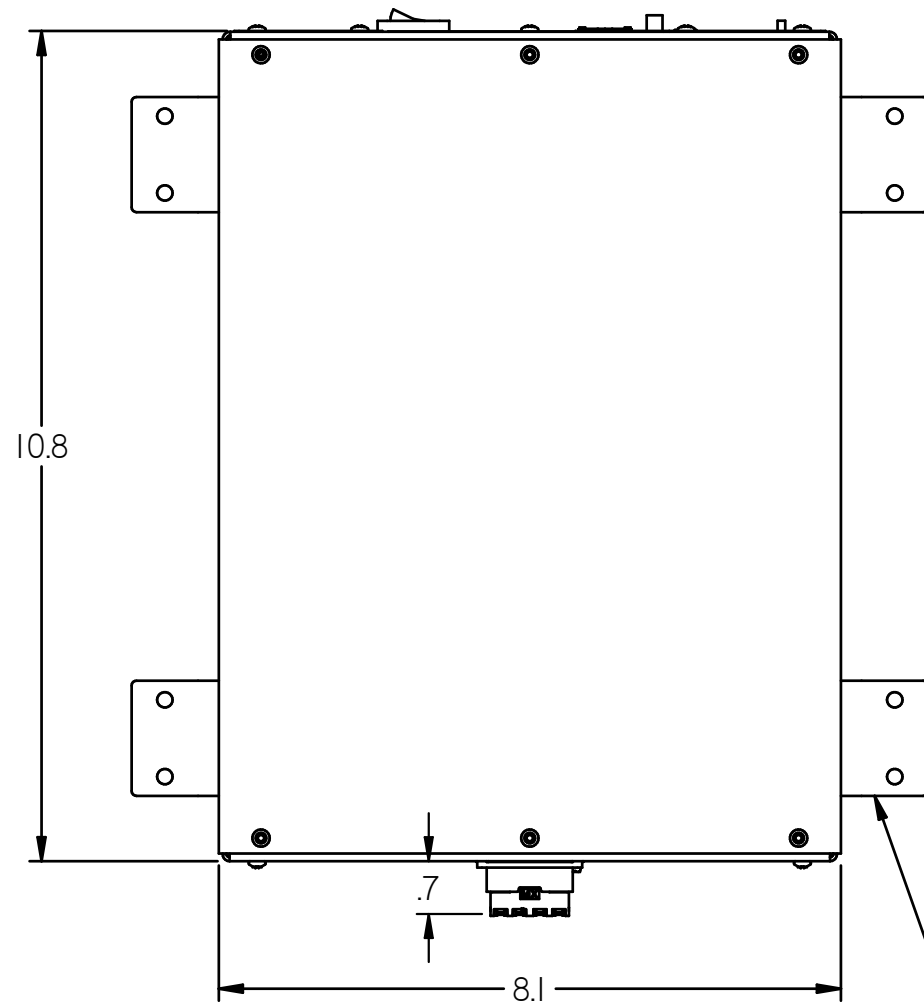

223905, OPTIONAL MOUNTING BRACKET KIT, NOTE 1

1) BRACKET ATTACHMENT SCREW PITCH = #10-24, MAXIMUM THREAD ENGAGEMENT INTO ENCLOSURE = 0.20"

**MICRON OPTICS PROPRIETARY**  
 THIS DOCUMENT CONTAINS MATERIAL AND/OR INFORMATION WHICH IS THE PROPERTY OF MICRON OPTICS, INC. IT IS SUPPLIED ONLY ON A PROPRIETARY BASIS, AND MUST BE RETURNED UPON REQUEST. DO NOT CIRCULATE, REPRODUCE OR DIVULGE TO OTHER PARTIES WITHOUT WRITTEN CONSENT OF MICRON OPTICS, INC.

**UNLESS OTHERWISE NOTED**  
 DIMENSIONS IN INCHES (MM)  
 INTERPRET DRAWINGS PER ASME Y 14.5 - 2009

**STANDARD TOLERANCES**  
 DECIMAL INCHES .X.XX = +/- .01 X.XXX = +/- .005  
 X.XXXX = +/- .0005 ANGLES +/- 2DEG  
 HOLE DIA = +/- .005 HOLE CL = +/- .010  
 FRAC IN 1 TO 36 = +/- .03 36 UP = +/- .06  
 MACHINED SURFACES = 125



Customer views, si155

PART NO		DRAWING NO	
NA		NA	
DRN BY	SIZE	SHEET 1 OF 2	
rwmock	B		

REVISION HISTORY			
REV	DESCRIPTION	DATE	EO NUMBER
1	Initial release	06/24/2015	NA
2	Added Note 1, sheet 1	12/02/15	



**MICRON OPTICS PROPRIETARY**  
 THIS DOCUMENT CONTAINS MATERIAL AND/OR INFORMATION WHICH IS THE PROPERTY OF MICRON OPTICS, INC. IT IS SUPPLIED ONLY ON A PROPRIETARY BASIS, AND MUST BE RETURNED UPON REQUEST. DO NOT CIRCULATE, REPRODUCE OR DIVULGE TO OTHER PARTIES WITHOUT WRITTEN CONSENT OF MICRON OPTICS, INC.



Customer views, si155

**UNLESS OTHERWISE NOTED**  
 DIMENSIONS IN INCHES (MM)  
 INTERPRET DRAWINGS PER ASME Y 14.5 - 2009

**STANDARD TOLERANCES**  
 DECIMAL INCHES .X.XX = +/- .01 X.XXX = +/- .005  
 X.XXXX = +/- .0005 ANGLES +/- 2DEG  
 HOLE DIA = +/- .005 HOLE CL = +/- .010  
 FRAC IN 1 TO 36 = +/- .03 36 UP = +/- .06  
 MACHINED SURFACES = 125

PART NO		DRAWING NO	
NA		NA	
DRN BY	SIZE	SHEET 2 OF 2	
rwmock	B		